

Series 800

AWWA Butterfly Valves





A Century of Experience

VAG GA Industries valves are known for long term reliability in the most demanding water and wastewater applications. Whether a simple check valve or a complex automatic control valve, each VAG GA Industries valve is built on over 100 years of design, manufacturing and application experience to ensure its dependability and superior performance.

Outstanding Technical Support

From the factory to the field, VAG provides responsive and knowledgeable technical assistance and support. VAG application engineers, and our team of trained and experienced sales representatives, work closely with designers to select the right valve from our broad product range to ensure the valve meets the system requirements. VAG is committed to serving our customers in all phases of the project.

Superior Quality

VAG GA Industries valves are designed in accordance with applicable AWWA and other industry standards and precision manufactured from the highest grade materials. Every valve is tested to ensure it meets our high standards and the latest industry requirements so you can be sure it will operate as expected from the minute it is put in service.

Comprehensive Product Range

We are continuously expanding and improving our product line to meet the ever-changing needs of the waterworks industry. From off-the-shelf standard butterfly and plug valves to sophisticated, highly engineered pump control, check and surge control valves, VAG offers one of the broadest ranges of valves specifically suited to the demanding needs of municipal waterworks.



Series 800

3"– 24" AWWA Butterfly Valves

The Series 800 Butterfly Valve represents over a century of engineering excellence, manufacturing expertise, and application know-how. Rugged, dependable, and versatile; these valves are found in water filtration and treatment plants, pumping stations, pipelines, power stations, and industrial complexes throughout North America.

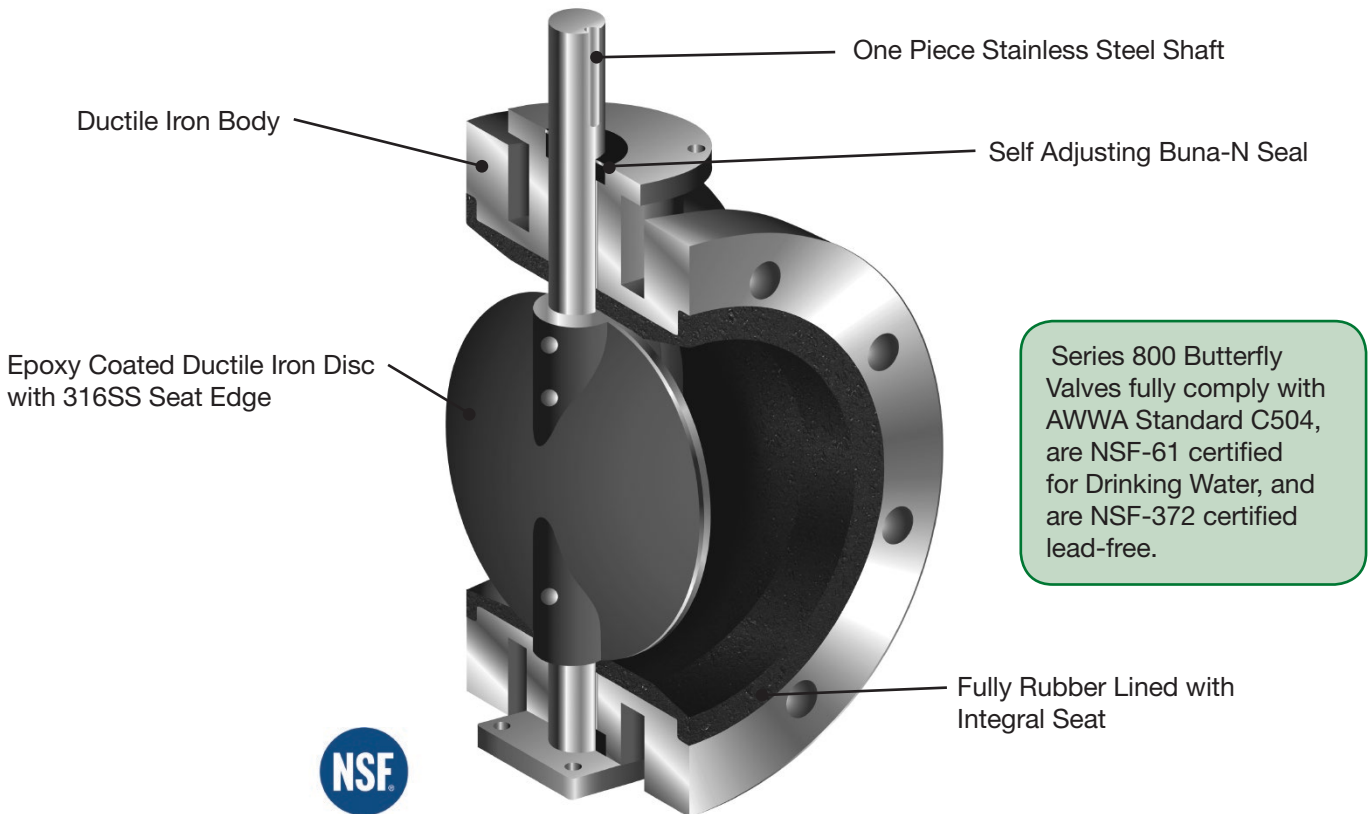

Body Style

3"– 24" Ductile Iron Body, 150-250PSI Rated ANSI B16.1, Class 125 Flanged, Mechanical Joint and Wafer valves available.

Rugged and Corrosion Resistant

High strength ductile iron and epoxy coating create long-term corrosion resistance, lengthening the life of the valve.

One Piece Stainless Steel Shaft

Standard stainless steel one-piece shaft for increased durability and performance.

Low Friction Bearings

Upper and lower bearings are self-lubricating stainless steel backed PTFE for low friction and exceptionally long life.

Long Term Tight Seating

The rubber seat is in the body and integrally molded with a rubber lining that is permanently vulcanized to the body.

Self-Adjusting Seals

Shaft seals are self-adjusting, wear compensating synthetic rubber for dependable sealing and long life.

Standard Actuator Mounting Pad

Series 800 butterfly valves are standard with an integrally cast actuator mounting pad that permits direct mounting of the manual and automatic actuators without the need for spool pieces and adaptors. This provides a more compact and rigid arrangement.

Tested and Certified

VAG GA Industries AWWA Butterfly Valves have undergone proof of design testing to ensure long-term dependability and every valve is rigorously tested before it leaves the factory.



3"- 24" ANSI Class 125 Flanged, AWWA C504 Class 150B & 250B



Standard Materials

Body	Epoxy Coated Ductile Iron, ASTM A536 Grade 65-45-12
Disc	Epoxy Coated Ductile Iron, ASTM A536 Grade 65-45-12 with 316SS Seat Edge
Seat	Standard: Buna-N Rubber, Molded and Vulcanized to the body Optional: EPDM Rubber, Molded and Vulcanized to the body
Shaft	Class 150B: Type 304 Stainless Steel (Standard) Class 150B: Type 316 Stainless Steel (Optional) Class 250B: Type 17-4PH Condition H1150 Stainless Steel
Shaft Bearings	Type 304SS Backed PTFE
Shaft Packing	Standard: Buna-N Rubber Optional: EPDM Rubber

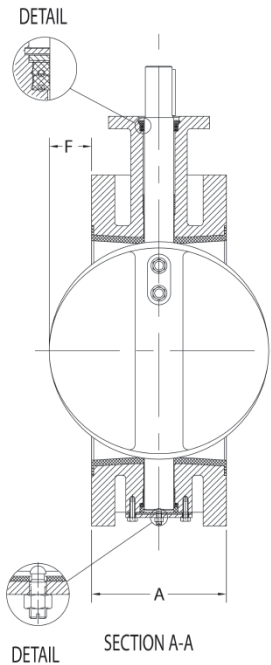
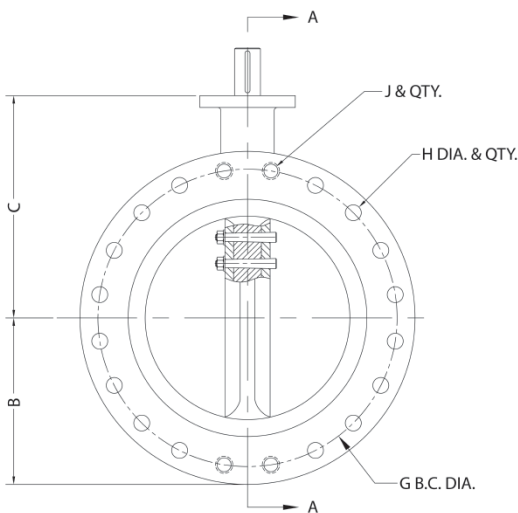

Dimensions (inches)

SIZE	A	B	C	F	G	H	J	WGT
3"	5.00	3.75	6.25	-	6.00	4 X 3/4	-	25
4"	5.00	4.50	7.00	-	7.50	8 X 3/4	-	40
6"	5.00	5.88	8.00	0.50	9.50	8 X 7/8	-	60
8"	6.00	6.75	9.50	1.00	11.75	8 X 7/8	-	90
10"	8.00	8.06	10.75	1.00	14.25	12 X 1	-	140
12"	8.00	9.50	12.31	2.00	17.00	12 X 1	-	190
14"	8.00	10.56	14.00	3.00	18.75	12 X 1 1/8	-	250
16"	8.00	12.31	15.00	4.00	21.25	12 X 1 1/8	4 X 1" - 8UNC	320
18"	8.00	13.00	16.50	5.00	22.75	12 X 1 1/4	4 X 1 1/8" - 7UNC	390
20"	8.00	14.62	18.00	6.00	25.00	16 X 1 1/4	4 X 1 1/8" - 7UNC	575
24"	8.00	17.12	22.50	8.00	29.50	16 X 1 3/8	4 X 1 1/4" - 7UNC	720

- Note:
1. Flange drilling per ANSI B16.1 Class 125 for Class 150B and 250B valves.
 2. Dimension F is minimum clearance required for valve to fully open
 3. 16" and larger valves have 4 tapped bolt holes in each flange, 2 at the top and 2 at the bottom, per Dimension G.
 4. Weight is in pounds and does not include actuator.

3- 24" Mechanical Joint, AWWA Class 150B & 250B



Standard Materials

Body	Epoxy Coated Ductile Iron, ASTM A536 Grade 65-45-12
Disc	Epoxy Coated Ductile Iron, ASTM A536 Grade 65-45-12 with 316SS Seat Edge
Seat	Standard: Buna-N Rubber, Molded and Vulcanized to the body Optional: EPDM Rubber, Molded and Vulcanized to the body
Shaft	Class 150B: Type 304 Stainless Steel (Standard) Class 150B: Type 316 Stainless Steel (Optional) Class 250B: Type 17-4PH Condition H1150 Stainless Steel
Shaft Bearings	Type 304SS backed PTFE
Shaft Packing	Standard: Buna-N Rubber Optional: EPDM Rubber

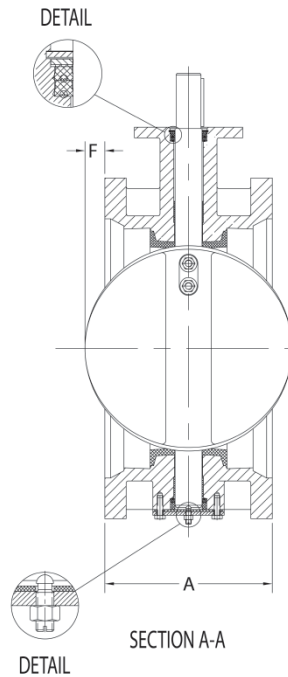
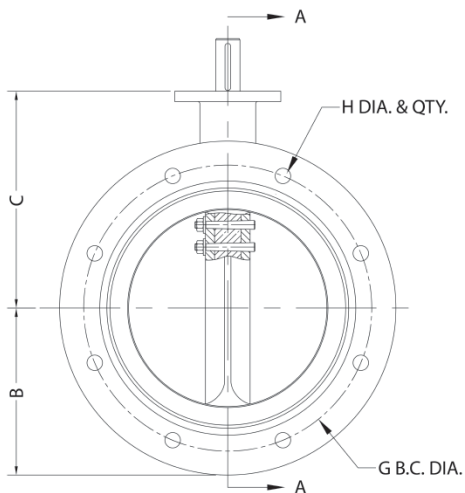

Dimensions (inches)

SIZE	A	B	C	F	G	H	WGT
3"	8.50	3.75	6.25	-	6.19	4 X 3/4	35
4"	8.50	4.50	7.00	-	7.50	4 X 7/8	40
6"	8.50	5.88	8.00	-	9.50	6 X 7/8	70
8"	8.50	6.75	9.50	-	11.75	6 X 7/8	95
10"	9.25	8.06	10.75	0.38	14.00	8 X 7/8	130
12"	9.25	9.50	12.31	1.38	16.25	8 X 7/8	175
14"	11.50	10.56	14.00	1.25	18.75	10 X 7/8	235
16"	12.00	12.31	15.00	2.00	21.00	12 X 7/8	325
18"	12.25	13.00	16.50	2.88	23.25	12 X 7/8	385
20"	12.50	14.62	18.00	3.75	25.50	14 X 7/8	475
24"	13.25	17.12	22.50	5.38	30.00	16 X 7/8	710

- Note: 1. MJ ends per AWWA C111/ANSI A21.11.
2. Dimension F is minimum clearance required for valve to fully open.
3. Weight is in pounds and does not include actuator.



3"- 20" Wafer, AWWA Class 150B



Standard Materials

Body	Epoxy Coated Ductile Iron, ASTM A536 Grade 65-45-12
Disc	Epoxy Coated Ductile Iron, ASTM A536 Grade 65-45-12 with 316SS Seat Edge
Seat	Standard: Buna-N Rubber, Molded and Vulcanized to the body Optional: EPDM Rubber, Molded and Vulcanized to the body
Shaft	Class 150B: Type 304 Stainless Steel (Standard) Class 150B: Type 316 Stainless Steel (Optional) Class 250B-Type 17-4PH Condition H1150 Stainless Steel
Shaft Bearings	Type 304SS backed PTFE
Shaft Packing	Standard: Buna-N Rubber Optional: EPDM Rubber

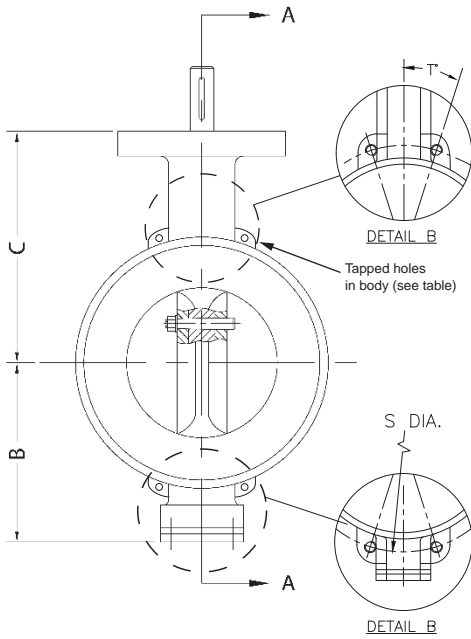

DETAIL

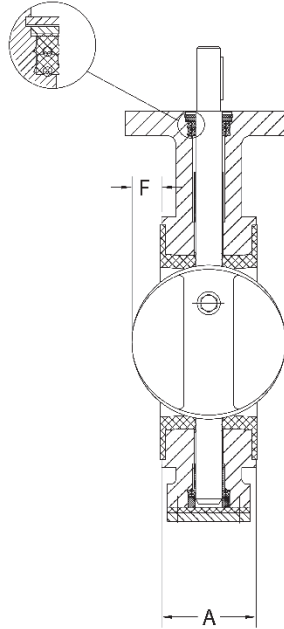

Dimensions (inches)

SIZE	A	B	C	F	WGT
3"	2.00	3.50	4.75	0.50	10
4"	2.25	4.25	5.50	0.88	13
6"	2.75	5.13	6.50	1.62	30
8"	3.00	6.25	7.88	2.50	42
10"	3.12	9.06	9.00	3.44	60
12"	3.37	9.84	10.56	4.31	92
14"	3.75	11.00	11.81	5.12	130
16"	4.12	12.63	13.44	5.94	190
18"	4.62	13.75	15.88	6.69	240
20"	5.12	14.56	16.75	7.44	310

Tapped Holes (Detail B)

SIZE	THREAD	SIZE	THREAD DEPTH	S DIA.	T°
16"	1- 8UNC		1.13	21.25	11.25°
18"	1½" - 7UNC		1.13	22.75	11.25°
20"	1½" - 7UNC		1.13	25.00	9.0°

- Note: 1. Dimension F is minimum clearance required for valve to fully open.
2. Weight is in pounds and does not include actuator.

3" - 24" Flow Coefficient (Cv) vs. Disc Angle

The flow coefficient of a device is a relative measure of its efficiency at allowing fluid flow. In more practical terms, the flow coefficient Cv is the volume (in US gallons) of water at 60°F that will flow per minute through a valve with a pressure drop of 1 psi across the valve.

SIZE	10°	20°	30°	40°	50°	60°	70°	80°	90°
3"	<1	3	28	43	65	91	113	147	186
4"	<1	4	34	76	135	222	312	355	378
6"	4	87	131	201	306	428	533	690	874
8"	6	104	291	446	679	950	1,183	1,532	1,939
10"	8	128	337	723	1,253	1,754	2,184	2,828	3,580
12"	10	142	415	804	1,456	2,491	4,305	6,069	6,700
14"	91	985	1,477	2,264	3,446	4,824	6,005	7,778	9,845
16"	124	1,373	2,060	3,159	4,807	6,730	8,378	10,850	13,734
18"	542	1,738	2,607	3,997	6,082	8,515	10,600	13,728	17,377
20"	921	2,203	3,304	5,066	7,710	10,794	13,437	17,402	22,028
24"	1,521	2,868	4,302	6,597	10,038	14,053	17,494	22,656	28,679

Actuation

Manual Actuators

- Worm gear actuators can withstand input torque of 300 ft-lbs
- Traveling nut actuators can withstand input torque of 450 ft-lbs
- Above ground actuators are standard with a visual position indicator and handwheel operator; chainwheel and 2" square nut are optional
- Buried service actuators are sealed, grease packed, and supplied with a 2" square nut
- Valves up to 8" can be supplied with 10-position lever operators



Electric Motor Actuators

- Available for all Series 800 Butterfly Valves
- Compact and rigid assembly
- For open/close or modulating service under any condition
- Mounts directly to the valve's integral MSS SP-101 pad
- No adaptors or spool pieces necessary

Cylinder Actuators

- Pneumatic or hydraulic cylinder actuators available
- Double-Acting (fail to close or fail to open) or single acting (spring return) types
- Control systems are available to accommodate open/close, pump control, and throttling application

Accessories

A full range of accessories are available to suit installation requirements including: extension stems with universal joints and stem guides, extended bonnets, torque tubes, floor stands, valve boxes, T-wrenches and more.



Series 800

24" and Larger AWWA Butterfly Valves

The 24" and Larger Butterfly Valve features a superior seating design that consists of stainless steel seat retainers and self-locking nuts that securely hold the rubber seat in place, while allowing easy seat adjustment and replacement using common tools. The Series 800 Butterfly Valve provides long-term dependable service and a truly field replaceable rubber seat, without a lengthy disruption in service.

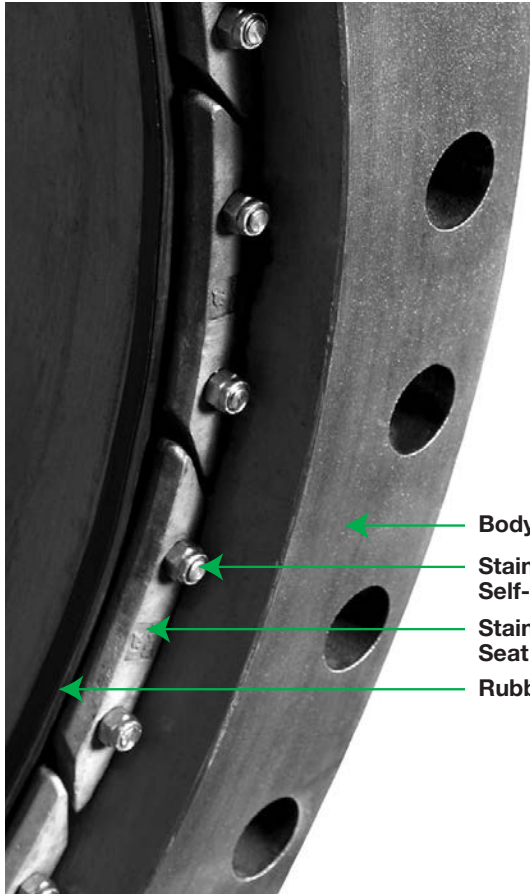

- ← Body
- ← Stainless Steel Self-Locking Nut
- ← Stainless Steel Seat Retainer
- ← Rubber Seat

CV Values - Full Open

SIZE	CV
24"	27,850
30"	42,000
36"	62,000
42"	79,000
48"	108,000
54"	131,355
60"	169,225
66"	212,435
72"	255,885

Body Style

24"-72", Class 150B, Ductile Iron, 150PSI Rated
 24" and Larger, Class 250B, Ductile Iron, 250PSI Rated
 ANSI B16.1, Class 125 Flanged or Mechanical Joint

Rugged and Corrosion Resistant

High Strength cast or ductile iron and epoxy coating create long-term corrosion resistance, prolonging the life of the valve.

Stainless Steel Shaft

Stainless steel shaft provides increased durability and performance.

Tight Seating and Low Operating Torque

The dome-shaped ductile iron disc has a precision machined 316 stainless steel seat edge for tight seating and low operating torque.

Low Friction Bearings

Upper and lower self-lubricating bearings provide low friction and long life.

Self-Adjusting Seals

Shaft seals are self-adjusting, wear compensating Buna-N, or optional EPDM, rubber for dependable sealing and long life.

Truly Field Replaceable Rubber Seat

Standard Buna-N, or optional EPDM rubber seat is locked in the body by Type 316 stainless steel retainers. Seat is easily adjustable and replaceable without special tools or equipment.

Tested and Certified

VAG GA Industries Series 800 Butterfly Valves are designed, manufactured, and tested to AWWA Standard C504, are NSF-61 certified for contact with drinking water, and are NSF-372 certified lead-free.



24" and Larger Flanged, AWWA C504 Class 150B and 250B



Standard Materials

Body	24"-72" Class 150B Epoxy Coated Ductile Iron, ASTM A536 Grade 65-45-12 Class 250B: Epoxy Coated Ductile Iron, ASTM A536 Grade 65-45-12
Disc	Epoxy Coated Ductile Iron, ASTM A536 65-45-12 with 316SS Seat Edge
Seat	Standard: Buna-N Rubber Optional: EPDM Rubber
Shaft	Class 150B: Type 304 Stainless Steel (Standard) Class 150B: Type 316 Stainless Steel (Optional) Class 250B: Type 17-4PH Condition H1150 Stainless Steel
Shaft Bearings	Self-lubricating Composite
Shaft Packing	Standard: Buna-N Rubber Optional: EPDM Rubber

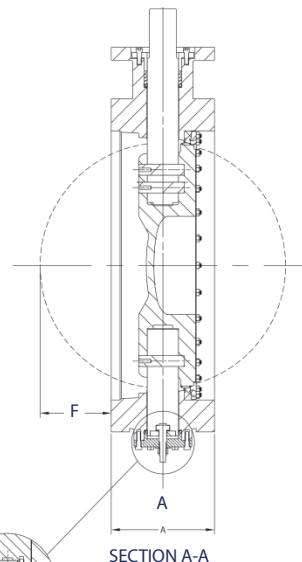
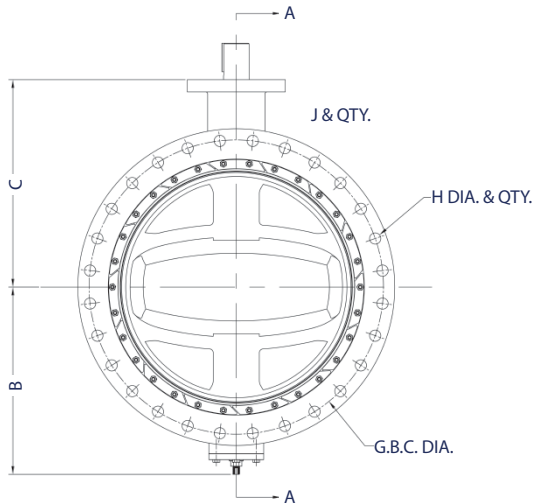

Dimensions (inches)

SIZE	A	B	C	F	G	H	J	WGT
24"	8.00	17.50	22.50	8.00	29.50	16 X 1 $\frac{3}{8}$	4 X 1 $\frac{1}{4}$ " - 7UNC	1,050
30"	12.00	22.91	25.44	9.00	36.00	24 X 1 $\frac{3}{8}$	4 X 1 $\frac{1}{4}$ " - 7UNC	1,450
36"	12.00	26.63	28.81	12.00	42.75	28 X 1 $\frac{3}{8}$	4 X 1 $\frac{1}{2}$ " - 6UNC	2,050
42"	12.00	29.68	31.00	15.00	49.50	30 X 1 $\frac{3}{8}$	6 X 1 $\frac{1}{2}$ " - 6UNC	3,000
48"	15.00	34.88	34.81	16.50	56.00	36 X 1 $\frac{3}{8}$	8 X 1 $\frac{1}{2}$ " - 6UNC	3,900
54"	15.00	37.83	40.20	18.27	62.75	36 X 2	8 X 1 $\frac{3}{4}$ " - 5UNC	5,400
60"	15.00	41.59	43.31	21.32	69.25	44 X 2	8 X 1 $\frac{3}{4}$ " - 5UNC	6,950
66"	18.00	46.13	47.00	23.09	76.00	44 X 2	8 X 1 $\frac{3}{4}$ " - 5UNC	8,700
72"	18.00	49.61	51.06	25.96	82.50	52 X 2	8 X 1 $\frac{3}{4}$ " - 5UNC	10,750

- Note:
1. Flange drilling per ANSI B16.1 Class 125 for both Class 150B and 250B.
 2. Dimension F is minimum clearance required for valve to fully open.
 3. Flanged valves have tapped bolt holes at top and bottom of both flanges.
 4. Dimension G indicates number and size of tapped holes.
 5. Weight is in pounds and does not include actuator.



24" and Larger Mechanical Joint, AWWA C504 Class 150B and 250B



Standard Materials

Body	Class 150B: Epoxy Coated Ductile Iron, ASTM A536 Grade 65-45-12 Class 250B: Epoxy Coated Ductile Iron, ASTM A536 Grade 65-45-12
Disc	Epoxy Coated Ductile Iron, ASTM A536 Grade 65-45-12 with 316SS Edge
Seat	Standard: Buna-N Rubber Optional: EPDM Rubber
Shaft	Class 150B: Type 304 Stainless Steel (Standard) Class 150B: Type 316 Stainless Steel (Optional) Class 250B: Type 17-4PH Condition H1150 Stainless Steel
Shaft Bearings	Self-lubricating Composite
Shaft Seals	Standard: Buna-N Rubber Optional: EPDM Rubber

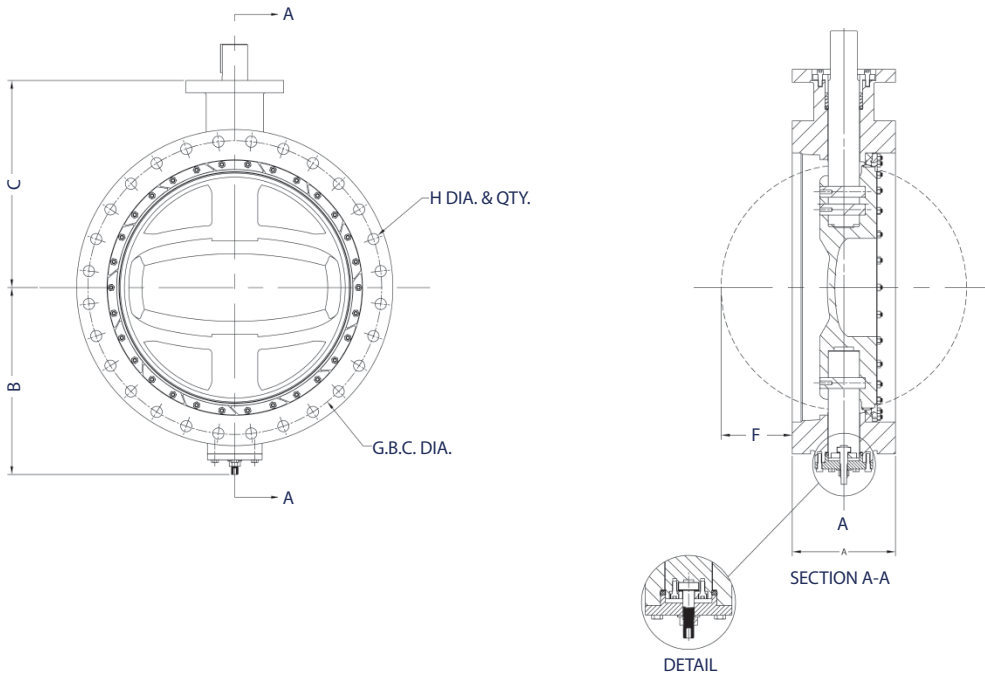

Dimensions (inches)

SIZE	A	B	C	F	G	H	WGT
24"	13.75	17.50	22.50	5.13	30.00	16 X 7/8	1,200
30"	18.00	22.91	25.00	6.00	36.88	20 X 1 1/8	1,650
36"	22.00	26.63	28.81	7.00	43.75	24 X 1 1/8	2,450
42"	22.50	29.68	31.00	9.75	50.63	28 X 1 3/8	3,350
48"	24.00	34.88	34.81	12.00	57.50	32 X 1 3/8	4,650

Note: 1. Mechanical joint ends per ANSI/AWWA C111/A21.11.
2. Weight is in pounds and does not include actuator.

Specification

AWWA C504 Rubber Seated Butterfly Valve

DESIGN

- A. Valves shall be in complete conformance with AWWA C504 (latest revision) for Rubber Seated Butterfly Valves. Butterfly Valves shall be bubble tight at full rated pressure and be capable of operation after long periods of inactivity.
- B. Valves shall be Pressure Class 150B unless otherwise specified. Flanged valves shall meet the AWWA C504 “short-body” face-to-face dimensions and be faced and drilled per ANSI B16.1 Class 125. Mechanical joint end butterfly valves shall conform to ANSI/AWWA C111/A21.11.
- C. Valve body shall conform to the minimum wall thickness requirements of AWWA C504 and have an integral ISO 5211/MSS SP-101 mounting flange for direct mounting of the manual or automatic actuator.
- D. The nominal size, pressure rating, date of manufacture and manufacturer’s name shall be cast onto the body or be on a permanently attached nameplate. The valve shall be NSF-61 certified for contact with drinking water and NSF-372 certified lead-free.

CONSTRUCTION CLASS 150B

- A. Sizes 3” to 24” shall be constructed as follows:
 - 1. Valve body shall be ASTM A536 Grade 65-45-12 ductile iron with a permanent Buna-N or EPDM rubber seat molded and vulcanized to the body. Flanged valves shall have a completely rubber lined waterway. Rubber seats retained by epoxy or adhesive are not acceptable.
 - 2. Valve discs shall be ASTM A536 Grade 65-45-12 ductile iron with a 316 stainless steel disc seat.
 - 3. The shaft shall be one piece Type 304 stainless steel for Class 150B (17-4PH SS for Class 250B) fastened to the disc with stainless steel pins to form a leak tight joint.
 - 4. The shaft shall have corrosion-resistant, self-lubricating upper and lower stainless steel 304 backed Teflon shaft bearings suitable for installation with the shaft vertical or horizontal and be sealed with multiple self-adjusting, replaceable rubber U-cup packing of the same material as the seat.
- B. Sizes 30” and larger shall be constructed as follows:
 - 1. Valve body shall be ASTM A536 Grade 65-45-12 ductile iron with Buna-N or EPDM rubber seat held in place by segmented Type 316 stainless steel retainers, studs, and self-locking nuts. The rubber seat shall be field adjustable and replaceable without the need for special tools or equipment. Rubber seats retained using epoxy or adhesive are not acceptable.
 - 2. Valve disc shall be the single offset type made from ASTM A536 Grade 65-45-12 ductile iron with a 316 stainless steel disc seat providing 360 degree uninterrupted seating.
 - 3. The valve shall have upper and lower stub shafts made from Type 304 stainless steel for Class 150B (17-4PH SS for Class 250B), fastened to the disc with stainless steel pins to form a leak tight joint.
 - 4. The upper and lower shafts shall have corrosion-resistant, self-lubricating composite bearings suitable for installation with the shafts vertical or horizontal. The upper shaft shall be sealed with multiple self-adjusting, replaceable rubber U-cup packing of the same material as the seat. A factory set, adjustable thrust bearing shall be provided beneath the lower shaft.

COATINGS

- A. Valves shall have internal ferrous surfaces coated with 8 mil of NSF-61 certified 2-part polyamide hi-build epoxy per AWWA C550.
- B. External ferrous surfaces except flange faces, shall have a primer coat of 2-part polyamide hi-build epoxy.

ACTUATORS

- A. Manually operated valves for above ground or exposed service shall be actuated by a worm gear or traveling nut actuator with a handwheel and visual position indicator.
- B. Manually operated valves for buried service shall be actuated by a sealed and grease-filled worm gear or traveling nut actuator with a 2” square nut. Buried service valves shall have all stainless steel external fasteners.
- C. When shown on the plans or valve schedule, the valve shall be operated by an electric motor, pneumatic or hydraulic cylinder actuator.

MANUFACTURER

- A. Rubber-seated butterfly valves shall be Series 800 as manufactured by VAG USA, LLC (VAG GA Industries brand), Cranberry Township, PA USA.

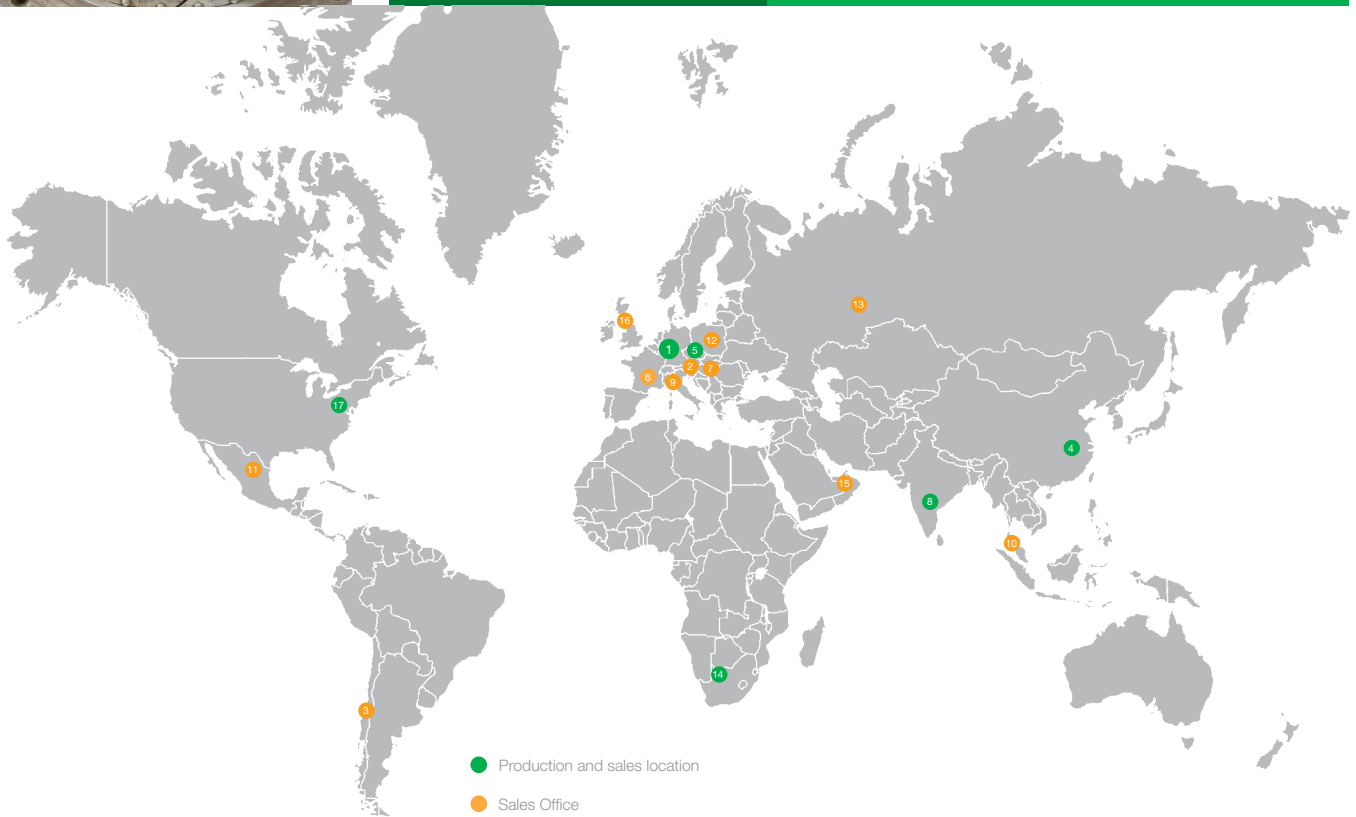

Locations

- | | | | |
|------------------------|-------------------|--------------------------------|-------------------|
| 1 GERMANY | MANNHEIM | 11 MEXICO | MONTERREY |
| 2 AUSTRIA | VIENNA | 12 POLAND | WARSAW |
| 3 CHILE | SANTIAGO DE CHILE | 13 RUSSIA | SAMARA |
| 4 CHINA | TAICANG | 14 SOUTH AFRICA (VAG/KLAMFLEX) | KRUGERSDORP |
| 5 CZECH REPUBLIC (JMA) | HODONIN | 15 UAE | DUBAI |
| 6 FRANCE | CHASSIEU | 16 UK | BIRMINGHAM |
| 7 HUNGARY | BUDAPEST | 17 VAG USA, LLC | CRANBERRY TWP, PA |
| 8 INDIA | HYDERABAD | | |
| 9 ITALY | SAN GIULIANO | | |
| 10 MALAYSIA | PETALING JAYA | | |

The VAG USA, LLC is part of a global network with our partner company, VAG-Armaturen GmbH, headquartered in Mannheim, Germany. Together, we have a highly qualified team of service specialists around the world. Our capabilities include:

- Engineering & technical design
- Production
- Fabrication
- Sales & distribution
- Installation & start-up
- Aftermarket service



VAG USA, LLC
9025 Marshall Road
Cranberry Twp., PA 16066

Phone: 724-776-1020
info-ga@vag-group.com
www.vag-usa.com

For international sales,
please contact our partner
company, VAG-Armaturen
GmbH, headquartered in
Mannheim, Germany.

www.vag-group.com