

200# WOG STAINLESS STEEL SWING CHECK VALVE

FIG. T2SC

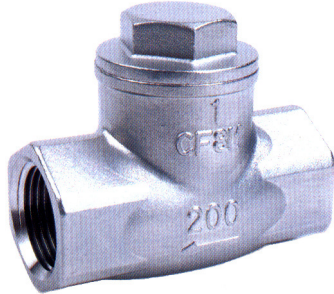

Ends: ANSI B1.20.1
 Size range: 1/4" to 2"
 Pressure 1/4" to 2": 200 psi (WOG)
 Max. Temperature: 350 °F
 Investment Casting
 Full Port
 Integral Seat
 Inspection & Testing: API 598

Materials:

No.	Part Name	Specification
1	Body	ASTM A351-CF8M
2	Cap	ASTM A351-CF8M
3	Disc	ASTM A351-CF8M
4	Hinge Pin	AISI 316
5	Gasket	PTFE
6	Pipe Plug	AISI 316

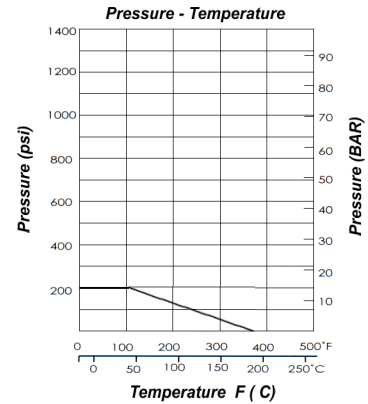
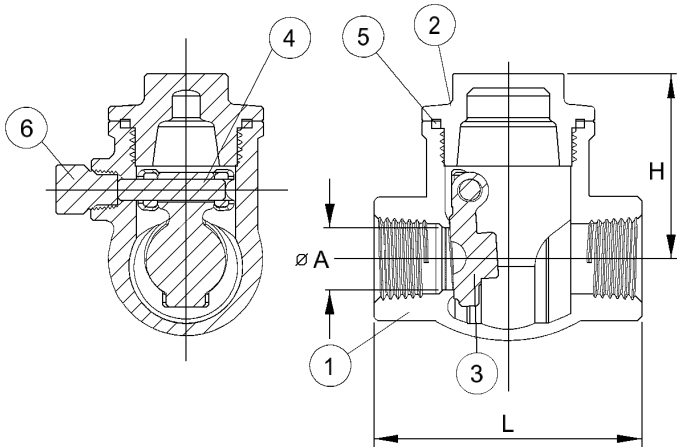

Dimensions:

Size		øA		L		H		CV	Weights	
in	mm	in	mm	in	mm	in	mm		lbs	kgs
1/4"	8	.39	10	2.56	65	1.77	45	-	.79	.36
3/8"	10	.47	12	2.56	65	1.77	45	5.5	.75	.34
1/2"	15	.59	15	2.56	65	1.77	45	8.9	.68	.31
3/4"	20	.79	20	3.15	80	2.17	55	16.6	1.1	.5
1"	25	.98	25	3.54	90	2.36	60	26.8	1.54	.7
1 1/4"	32	1.26	32	4.13	105	2.56	65	45.2	2.31	1.05
1 1/2"	40	1.57	40	4.72	120	2.95	75	72.5	3.52	1.6
2"	50	1.97	50	5.51	140	3.15	80	122	5.17	2.35